

**Main voltage:** 3VDC、 6VDC、 9VDC、 12VDC、 24VDC、

**Typical applications:** Pan/Tilt cameras, Grill, Oven, Cleaning machine, Garbage disposers, Packing bank note machine, Coffee machine, Medical machine, Manostat, Amusement equipment, infusion pumps, Office equipment, Household appliances, Automatic

**Weight:** 520~760g/pcs(approx)

**Packing details:** CTN size: 34X31XH15cm 20pcs/CTN G.W.16Kgs

**APPEARANCE SIZE**

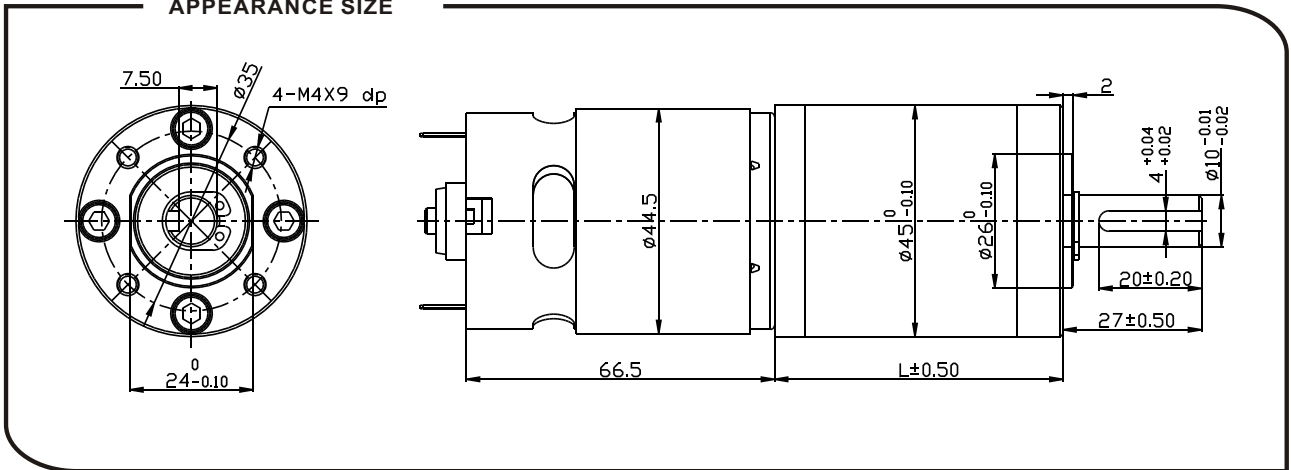

**Gearbox data:**

Number of stages	1 stages reduction	2 stages reduction	3 stages reduction	4stages reduction	5stages reduction
Reduction ratio	3.7, 5.2	13.7, 19.2, 26.9	50.9, 71.2, 99.5, 139, 236	188, 264, 369, 516, 721	699, 977, 1367, 1911, 2672, 3737,
Gearbox length "L" mm	33.6	44.9	56.2	67.5	78.8
Max. Running torque	6.0Kgf · cm	12Kgf · cm	20Kgf · cm	30Kgf · cm	50Kgf · cm
Max. Gear breaking torque	18Kgf · cm	36Kgf · cm	60Kgf · cm	90Kgf · cm	150Kgf · cm
Max. Gearing efficiency	90%	81%	73%	65%	59%

**Motor data:**

Motor name	Rated Volt. V	No load		Load torque			Stall torque		
		Current	Speed	Current	Speed	Torque	Output power	Torque	Current
		mA	r/min	mA	r/min	gf · cm	W	gf · cm	A
RS-775123000	12	≤220	3000	≤1000	2200	350	7.7	1400	3.5
RS-7751245 00	12	≤450	4500	≤2000	3300	500	16.5	2000	6.5
RS-775126000	12	≤900	6000	≤4000	4500	750	34	3000	13.0
RS-775243000	24	≤110	3000	≤500	2200	350	7.7	1400	1.8
RS-775244500	24	≤230	4500	≤1000	3300	500	16.5	2000	3.3
RS-775246000	24	≤450	6000	≤2000	4500	750	34	3000	7.0

1. This table lists some motors parameters, others please refer to specific parameters of Page 149.
2. After connecting motor and gearbox which is named gearmotor the output torque: motor torque X reduction ratio X gearing efficiency; output speed: motor speed / reduction ratio.